

Spec.No. KRF40A-VB-04E-1

ORION Trade Name DRY PUMP

ORION Model KRF40A-VB-04

Date February.18.2011

APPD	CKD		DWN
<i>Y</i>	<i>F</i>	<i>N</i>	<i>Y</i>
<i>Kuroiwa</i>	<i>Yamada</i>	<i>Takei</i>	<i>Takahashi</i>

ORION MACHINERY CO., LTD.

1. Warranty

(1) Warranty information

If by some chance breakdown or failure should occur within the warranty period and if it is clear that the cause of the problem rests with ORION, the item in question will be repaired without charge in accordance with the details below. Please note: This agreement is restricted to equipment used in Japan. However, items not specifically included in this warranty shall be replaced at the expense of the customer at the actual cost of those items. (Additional costs to transport such items and transportation costs for service personnel will be added as necessary.)

(2) Warranty period

The product shall be warranted for a period of one year from the date of purchase, or for 5000 hours of operation, whichever comes first.

(3) Items exempted from warranty

- (a) Consumable parts and periodic replacement parts.
- (b) Fault caused by careless handling or improper use and maintenance. (Operation not following the specifications and the instruction manual. Operation under abnormal environmental conditions.)
- (c) Fault caused by fire, flood, lightning stroke, abnormal voltage or unforeseen disasters.
- (d) Fault caused by repair or modification not performed by ORION or ORION authorized service contractors.
- (e) Change of appearance, such as damage or deterioration caused in general use.
- (f) Secondary damages caused by the fault (Incidental damages such as loss, inconvenience, and commercial loss resulting from the failed product).

(4) Product Use Limitations

- (a) If the unit is to be used as part of critical installations, safety devices and backup systems which can be switched to should be put into place to insure that serious accidents or losses do not occur in the event that the unit should break down or malfunction.
- (b) This product was designed and produced as a general purpose device for use in ordinary manufacturing. Accordingly, this warranty does not apply to nor cover the following applications. However, in cases where the customer/user takes full responsibility and confirms the performance of the equipment in advance, and takes necessary safety precautions, please consult with ORION and we will consider if use of the unit in the desired application is appropriate.

Atomic energy, aviation, aerospace, railway works, shipping, vehicles (cars and trucks), medical applications, transportation applications, and/or any applications where it might have a great effect on human life or property.

Electricity, gas, or water supply systems, etc. where high levels of reliability and safety are demanded

(Note) In case of a fault or an accident, contact the dealer with the model name and serial number.

2. Consumable parts / Periodic replacement parts

(1) Consumable parts (Parts to be replaced depending on the state at the time of inspection)

Name of Parts	Parts Number	Qty/ unit	Inspection period	Replacement criterion
Filter element (Inlet side)	04009779010	1	1 week	When damaged, or dirt cannot be removed by blowing air.
Delivery element (Exhaust side)	04044334010	1	1 week	When damaged, or dirt cannot be removed by blowing air.
Gasket (B)	04009579010	2	Removal of SD case	When damaged or worn.
Washer	33000300020	2	Removal of SD case	When damaged or worn.
O-ring	35152100050	2	Replacement of element	When damaged or worn.
Gasket	04100818010	2	Removal of cap	When damaged or worn.
Spring shaft	04100817010	2	Replacement of element	When damaged or worn.
Spring tube	04039359010	1	Replacement of element	When damaged or worn.
Liner *1	040000400 0	To be decided by actual positioning	Replacement of vane	When damaged.
Spider	0400620010	1	6 months	When damaged or crushed.

*1 The second digit from the right is subject to thickness.

0.2t(white) 1, 0.1t(black) 2, 0.05t(yellow) 3, 0.03t(red) 4

(2) Maintenance of plastic parts affecting safe operation

Replace the following plastic parts that may affect safe operation promptly when any damage or deformation is found. Failure to do so may cause injury.

Name of Parts	Parts Number	Qty/ unit
Main cover assembly	03103235010	1

(3) Replacement parts (Parts to be replaced at regular time intervals)

Name of Parts	Parts Number	Qty / unit	Replacement time	
			Vacuum 60kPa operation	Vacuum 80kPa operation
Vane	04100889010	5	8,500	6,500
Bearing	0A000229000	2	8,500	6,500

* The indicated blade replacement period is recommended in order to help prevent breakdown due to blade wear, and assumes average blade wear at 60Hz operation; specific performance is not guaranteed. The blade should be replaced soon if performance decreases or noise levels increase.

* When vanes are replaced, replace bearing at the same time. Use ORION specified bearings that are lubricated with special grease.

* Use the maintenance kit for replacement parts.

Name of Parts		Unit	Maintenance kit Assembly 40
Model			KRF40A
Parts no.			04100313010
Items	Vane	Pcs/Unit	5
	Bearing		2
	Liner (white)		4
	Liner (black)		4
	Liner (yellow)		6
	Liner (red)		8

(4) Motor Maintenance Cycle (An estimated indication of when motor replacement might be necessary. Actual motor lifetime will depend on specific operating conditions.)

Part Name	Part Number	Specifications	Qty	Maintenance Cycle
Motor	0A002458000	Three phase 1.1kW 4P	1	20,000h

* Indicates the time when the chance of failure due to wear increases. The motor does not necessarily require replacement after this time; the actual replacement time will depend on the operating conditions and environment of the particular installation. Please have the motor replaced when operation becomes abnormal.

3. Specifications

Model		KRF40A-VB-04	
Frequency		Hz	50 60
Designed capacity *1		L/min	575 685
Continuous operative vacuum	Recommended range *2	kPa	Vacuum and pressure in total: 60 or less
	Maximum value *3	kPa	Vacuum and pressure in total: 80kPa
Diameter of piping connection			Rc3/4
Motor		Phase / output/ pole	Three-phase / 1.1kW / 4P
		Frame no. / heat resisting class	80M / E
		Frequency / Rated voltage – current	50Hz / 380V – 2.7A 400V – 2.7A 415V – 2.7A 60Hz / 400V – 2.5A 440V – 2.5A 460V – 2.5A
Thermal set value *4		A	50Hz / 380V – 3.0A 400V – 3.0A 415V – 3.0A 60Hz / 400V – 2.8A 440V – 2.8A 460V – 2.8A
Mass		kg	36
Painting color			Black (except motor)
Installation condition (Suction air)		Installation site	Indoor
		Permissible ambient temperature deg.C	0 to 40
		Permissible ambient humidity %RH	65 ± 20 (JIS Z8703)
		Conditions	Corrosive or explosive gas must not exist in ambient atmosphere. Clean air with less dirt and dust, free of vapor and dew condensation.
Operation noise *5		dB	66 67

*1 Designed Pumping Capacity: Theoretical value calculated from volume. Refer to Performance Data for actual flow rate.

*2 Recommended range: Vacuum/pressure range the pump can exert its optimal performance (life, operation noise, etc.). In case high degree of vacuum/pressure is not required, operate at recommended range.

*3 Maximum value: The maximum degree of vacuum/pressure pump can continuously run. Do not operate pump continuously over this limit. Doing so will shorten pump life and can lead to premature failure or accidents.

*4 Setting for thermal protection is only as a guide regardless of variations of product performance.

*5 Operating noise level is only an actually measured value under continuous operational vacuum and continuous operational pressure, and not guaranteed.

EC DECLARATION OF CONFORMITY



ORION

ORION MACHINERY CO., LTD.
Phone +81-26-245-8537 Facsimile +81-26-245-4151
246 Oaza Kotaka, Suzaka-shi, Nagano-ken, 382-8502 JAPAN

EC DECLARATION OF CONFORMITY

We hereby declare that the following our product conform with the essential health and safety requirements of EEC Directives.

Product : DRY PUMP
Model No. : KRF Series
(KRF15, KRF25, KRF40, KRF15A, KRF25A, KRF40A
KRF04A, KRF08A, KRF70, KRF110)
Manufacturer : ORION MACHINERY CO., LTD.
246 Oaza Kotaka, Suzaka-shi, Nagano-ken,
382-8502 JAPAN
Directives : Machinery Directive 98/37/EC and 2006/42/EC
Low Voltage Directive 2006/95/EC

The above product has been evaluated for conformity with above directives using the following European standards. The technical construction file (TCF) for this product is retained at the above manufacturer's location.

Machinery Directive / Low Voltage Directive:
EN ISO12100-1:2003, EN ISO12100-2:2003, EN ISO14121-1:2007,
EN 1012-2:1996, EN 60204-1:2006, EN ISO13732-1:2006, EN 983:1996
others

Signature : 
Date : 2009.05.25
Name/Title : Toru Kaneko/General Manager

Being the responsible person appointed and employed by the manufacturer.

4. Precautions

- (1) Observe precautions, and operate the product within specifications.
- (2) Read the instruction manual prior to installation, operation, maintenance and inspection of the product. Especially pay attention to safety.
- (3) The vanes may get damaged if the residual pressure reverses the rotation when the pump stops. A check valve must be installed within 50 cm from the inlet port or exhaust port for protection.
- (4) Be sure to install the product horizontally on the flat surface.
- (5) Operating the product in an enclosed space may cause malfunction due to heat generated from the pump. Provide good ventilation around the product, so the ambient temperature does not exceed the permissible level.
- (6) Be sure to clean the filters periodically. Failure to do so may cause clogging and result in trouble due to overload.
- (7) Wiring work has to be performed by qualified personnel according to applicable laws and in-house regulations.
- (8) Be sure to install an overload protection such as a thermal relay in the electric circuit.
- (9) Allowable intermittent power supply voltage fluctuation range is $\pm 10\%$ of the specified voltage; allowable sustained supply voltage fluctuation range is $\pm 5\%$ of the specified voltage.
- (10) Be sure to use the product 1,000m or below above sea level.
- (11) Be sure to install the product on the level while whole base is touching on the level surface like in following figure A. If whole base is not touching on the level surface like in following figure B, be sure to put reinforcement plates under the base to prevent the base straining.

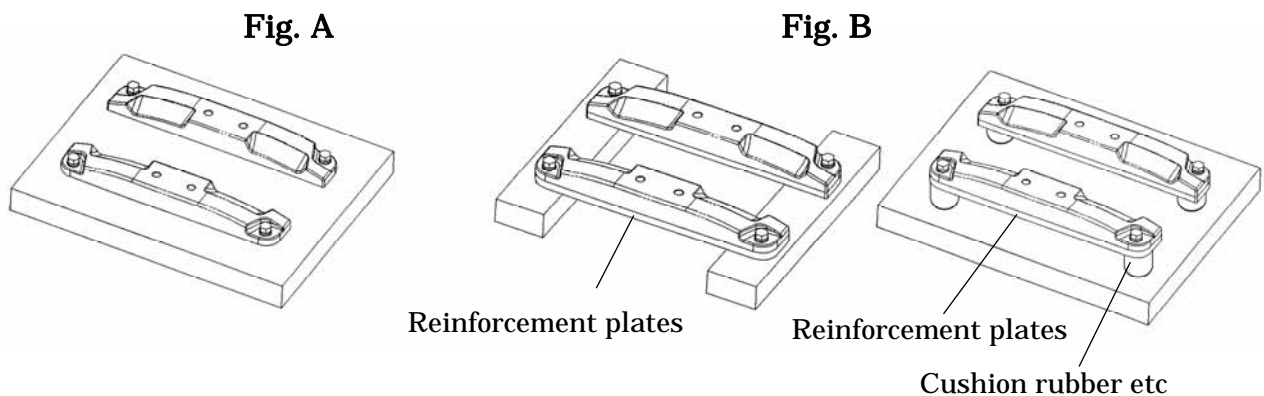

5. Accessories

D type compound gauge	60	2 piece
Vacuum controller (VC63B)		1 piece
Pressure controller (PCA6)		1 piece
Reinforcement plate		2 piece

6. Pressure-Flow rate diagram

KRF40A - VB - 04
Vacuum Specification

(Note) In case exhaust pressure is 0kPa

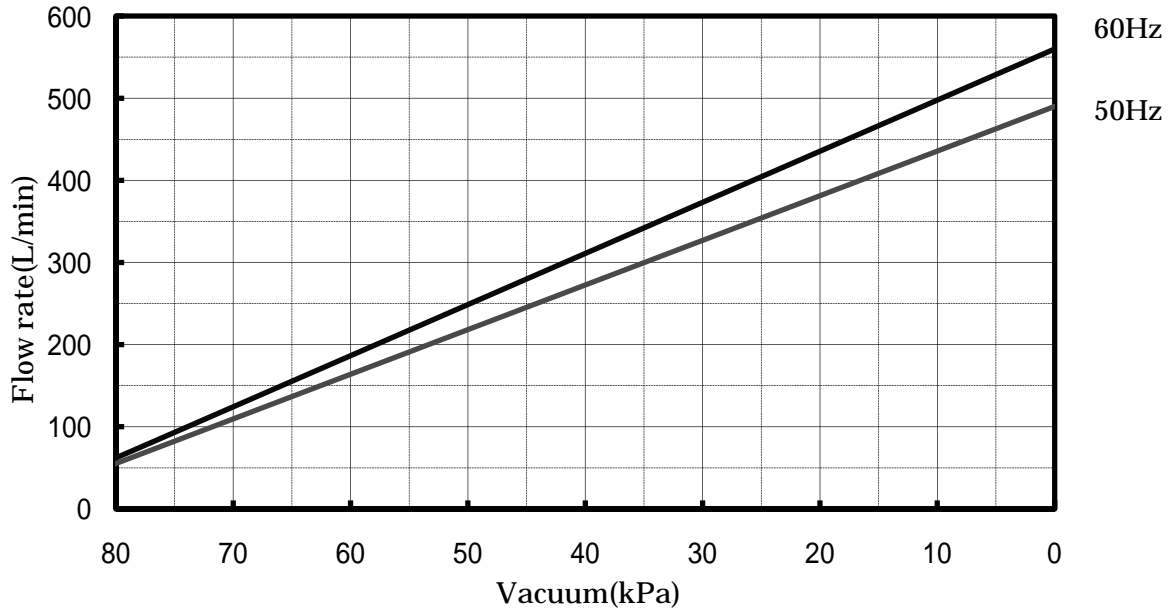

Pressure Specification

(Note) In case vacuum is 0kPa

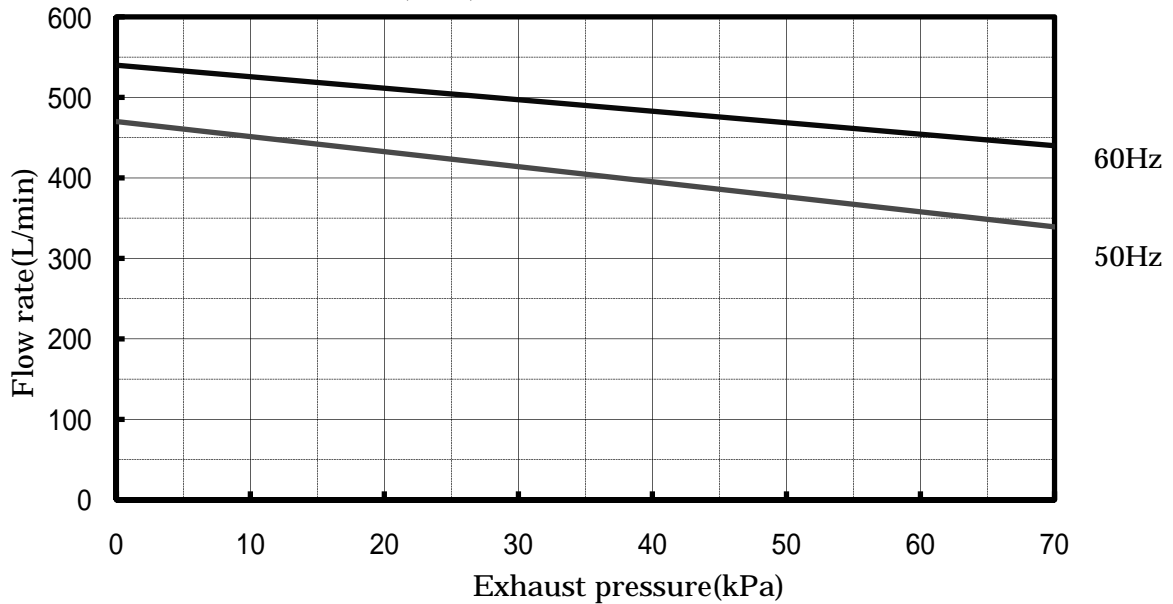

Condition: under 1 atmospheric pressure

20 deg.C

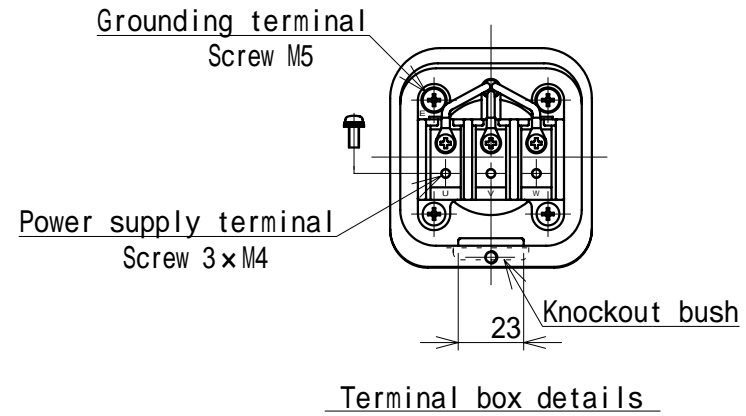
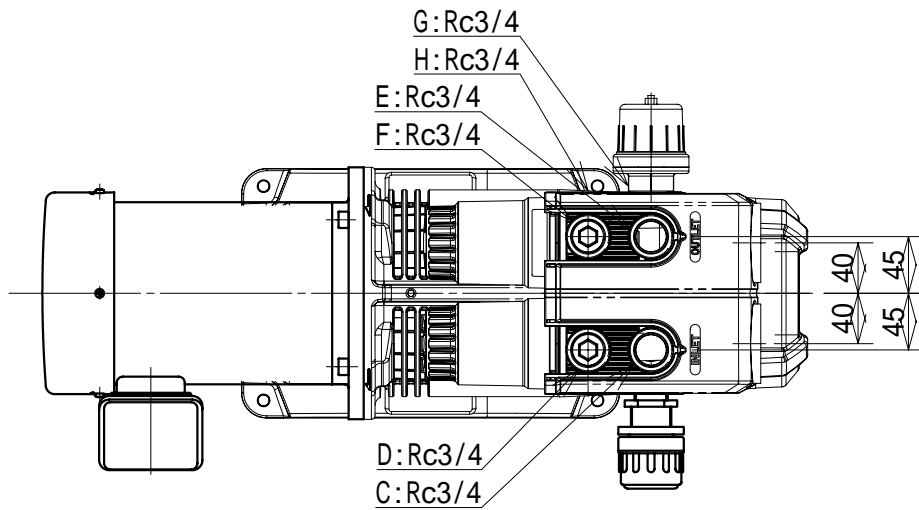

- 8 -

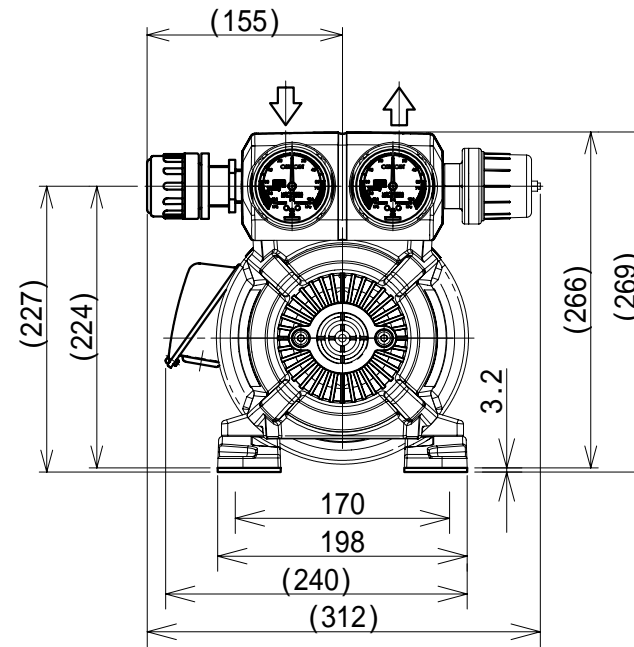
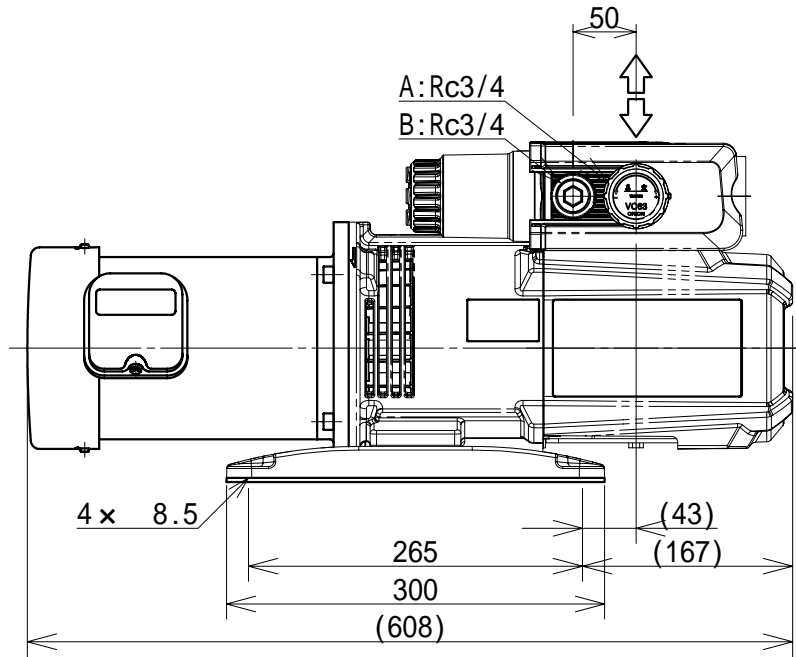

* In case reinforcement plates is sttached.

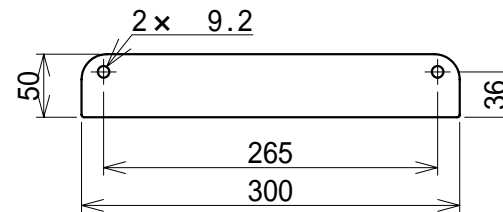

Details of reinforcement plate.

* The controller and the inlet port can be attachable to A, B, C, and D. The pressure controller can be attached to E, F, G, and H. However, the outlet port can only be attached to G and E.